

External Retaining Rings

C-Rings/E-Rings Japanese Standard

Code	Material		Hardness	Surface Treatment
C-Rings	GB	Equiv.		
TBP02	3Cr13	SUS420J2	34~42HRC	—

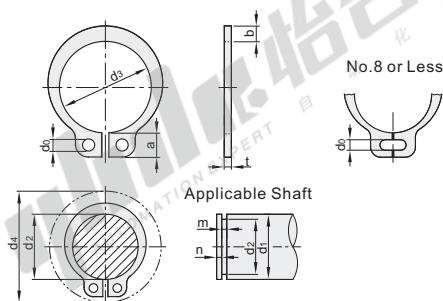

① d₄: Maximum outer diameter when retaining ring is fitted on d₁(Clearance outer diameter).
 ② Applicable Standards: JIS B 2804-2001

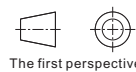

C-Rings

Part Number	Code	No.	Retaining Ring						Applicable Shaft(Reference)					
			d ₃	t	b(≈)	a(≈)	d ₀ (min.)	d ₄	d ₁	d ₂	m	n(min.)		
TBP02	5	4.7	+0.04 -0.15	0.6	1.1	2.4	0.8	10.5	5	4.8	0	0.7	0.3	
	6	5.6		0.7	1.3	2.8		12	6	5.7	-0.04	0.8		
	7	6.5	+0.06 -0.20	0.8	1.4	3	1	14	7	6.7	0	+0.1 0	0.5	
	8	7.4			1.6	3		15	8	7.6	-0.06	0.9	0.6	
	9	8.4			1.8	3.2		16	9	8.6	0			
	10	9.3				3		17	10	9.6	-0.09			
	11	10.2	±0.15		2	3.1	1.2	18	11	10.5	0			
	12	11.1		1	±0.05	2.1	3.2	19	12	11.5	0			
	13	12					3.3	20	13	12.4	0	1.15		
	14	12.9				2.2	3.4	22	14	13.4	-0.11			
15	13.8	±0.18				3.5	23	15	14.3	0		1.5		
16	14.7				2.2	3.6	24	16	15.2	0				
17	15.7					3.7	25	17	16.2	0				
18	16.5				2.6	3.8	26	18	17	0				
19	17.5					3.9	27	19	18	0				
20	18.5				2.7	4	28	20	19	0				
21	19.5					4.1	30	21	20	0	1.35			
22	20.5		1.2			4.2	31	22	21	0				
24	22.2				2.9	4.3	33	24	22.9	-0.21	+0.14 0	1.7		
25	23.2	±0.2		±0.06	3.1	4.4	34	25	23.9	0				
26	24.2					4.6	35	26	24.9	0				
28	25.9					4.7	38	28	26.6	0				
29	26.9				3.5	4.8	39	29	27.6	0		2.1		
30	27.9					5	40	30	28.6	0	1.65			
32	29.6		1.5			5.3	43	32	30.3	0		2.6		
34	31.5				4	5.4	45	34	32.3	0				
35	32.2	±0.25				5.6	46	35	33	0				
36	33.2					5.8	47	36	34	0				
38	35.2					6.2	50	38	36	0		3		
40	37				4.5	6.3	53	40	38	0				
42	38.5		1.8			6.6	55	42	39.5	-0.25	1.95			
45	41.5					6.7	58	45	42.5	0				
47	43.4	±0.4			4.8	6.8	61	47	44.5	0		3.8		
48	44.5					7	62	48	45.5	0				
50	45.8					7.1	64	50	47	0				
52	47.8				5	7.2	66	52	49	0				
55	50.8					7.4	70	55	52	0				
56	51.8		2			7.8	71	56	53	0	2.2			
58	53.8				5.5	7.7	73	58	55	0		4.5		
60	55.8	±0.45				7.4	75	60	57	-0.3	+0.14 0			
65	60.8					7.8	81	65	62	0				
68	63.5				6.4	8.2	84	68	65	0	2.7			
70	65.5		2.5	±0.08			86	70	67	0				
80	74.5				7.4	8.2	97	80	76.5	0		5.3		
105	98	±0.55	4	±0.09	9.5	9.8	125	105	101	-0.54	4.2	+0.18 0	6	



Part Number	
Code	No.
TBP02	5
	6

TBP02 — 5



Discount price
 Per 1~499 500~
 Price 100% Additional quotation



Delivery
 4

