

XY-Axis, Standard ▶ Micrometer Head

Economy Cross Roller Guide Stages



Code	Type	Drive Direction	Material	Surface Treatment
E-EIC31	Micrometer Head	Standard	Aluminum Alloy	Black Anodize

- ① The cross guide rail and differential head may rust during installation and use. Please pay attention to taking rust prevention measures.
- ② The cross roller guide rail has weak impact resistance. If it dropped or too much force is applied to it, abnormal sliding will occur. Please pay full attention when using it.

No.: 40

No.: 60

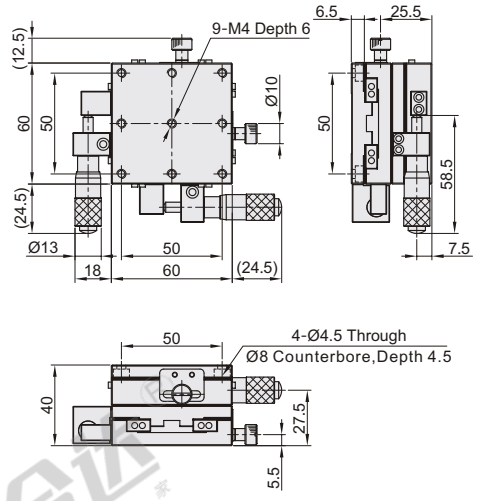
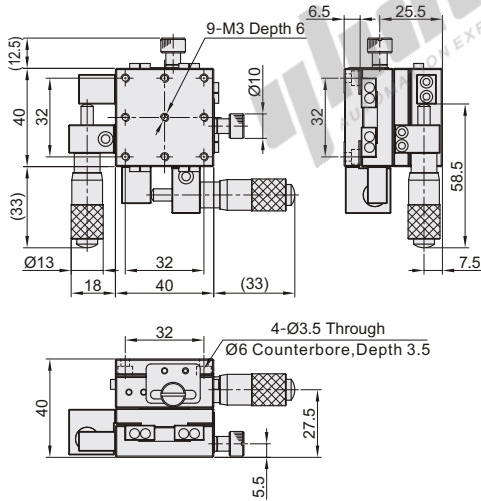

No.: 80

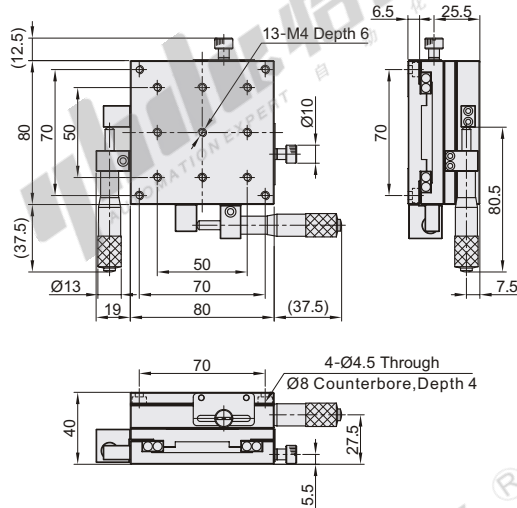

Part Number		Stage Surface (mm)	Drive Position	Travel Distance (mm)	Minimum Graduation (μm)	Travel Accuracy (Parallelism) (μm)	Load Capacity (kgf)	Body Weight (kg)
Code	No.							
E-EIC31	40	40×40	Side	±6.5	10	80	2	0.28
	60	60×60					5	0.51
	80	80×80					10	1



Code	QR	QC
Spec.	<p>Micrometer changed to left and right (reverse) position</p> <p>Ordering Code QR</p>	<p>Micrometer changed to center position</p> <p>Ordering Code QC</p>



Part Number	Stage Surface (mm)
Code	No.
E-EIC31	40
E-EIC31	60

E-EIC31-40

Optional Processing

Part Number	Optional Processing
Code	No.
E-EIC31	40
E-EIC31	60

E-EIC31-40-QR