

2-Hole / 2-Tapped (Coarse) ▶ Slit Type

Shaft Collars



Code	Type	Material		Surface Treatment	Accessories			
		GB	Equiv.					
FAJ01	2-Hole	45	S45C	Black Oxide	Hex Socket Head Cap Screw 1 pc.			
FAJ02				Fine Sandblasting Electroless Nickeling	Hex Socket Head Cap Screw 1 pc. (Stainless Steel)			
FAJ51	Slit Type	0Cr18Ni9	SUS304	—	—			
FAJ52				2-Tapped	45	S45C	Black Oxide	Hex Socket Head Cap Screw 1 pc.
FAJ56							Fine Sandblasting Electroless Nickeling	Hex Socket Head Cap Screw 1 pc. (Stainless Steel)

- ① If there is requirement of rust prevention, please choose stainless steel materials or electroless nickel-plated products firstly.
- ② Due to the different production batches of products, nickel plated products may have fine sand blasting, which does not affect the size and function.
- ③ Due to different production batches, the fine sandblasted electroless nickel-plated products may not be sandblasted when shipped, which does not affect the size and function.
- ④ Due to production process reasons, there will be a threaded fastening hole at the end of the threaded hole of the stainless steel fixing collar body, which does not affect the size and function.

2-Hole
FAJ01/02/06

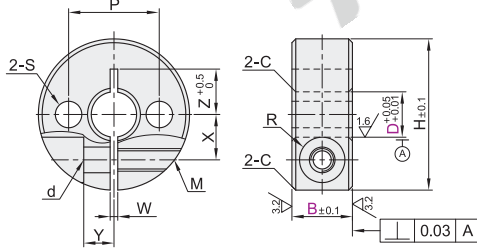

2-Tapped
FAJ51/52/56

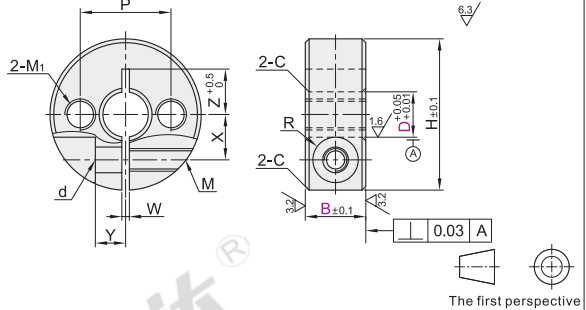

Part Number		B	H	M	d	R	W	X	Y	Z	S	P	M ₁	C			
Code	D																
2-Hole FAJ01 FAJ02 FAJ06	6	8*	20	M3	3.4	3	1	6	4	6~6.5	3.5	12	M3				
		10*		M4	4.5	3.75						13					
	8	8*	25	M3	3.4	3				8		5	7~9		4.5	14	M4
		10*		M4	4.5	3.75										18	
		12*		M5	5.5	4.5							7~10		5.5	20	—
		15		M6	6.6	6											
	10	8*	30	M3	3.4	3		9		6	8~10	6.6	24		—		
		10*		M4	4.5	3.75							20		M5		
		12*		M5	5.5	4.5					8~12	5.5			22	—	
		15		M6	6.6	6											
	12	8*	35	M3	3.4	3		10		5	9~10	5.5	22		M5		
		10*		M4	4.5	3.75							20		M6		
12*		M5		5.5	4.5	9~12	6.6				24	M4					
15*		M6		6.6	6						22	M5					
13	10*	30	M4	4.5	3.75	10		6	10	4.5	22	M4					
	12*		M5	5.5	4.5						20	M5					
	15		M6	6.6	6				10~12	5.5		23	M5				
	15		M6	6.6	6						24	—					
15	10*	34	M4	4.5	3.75	1.5	11.5	6	10~11	4.5	23	M4					
	12*		M5	5.5	4.5						20	M5					
	15*		M6	6.6	6				11~13	6.6		28	M6				
	15*		M6	6.6	6						24	M4					
16	10*	35	M5	5.5	4.5	1.5	12	6	11~12	4.5	24	M4					
	12*		M6	6.6	6						20	M5					
	15*		M6	6.6	6				11~13	6.6		26	M6				
	15*		M6	6.6	6						28	M4					
2-Tapped FAJ51 FAJ52 FAJ56	10*	40	M5	5.5	4.5	1.5	14	7	13	4.5	28	M4					
	12*										30	M5					
	15*								30	M6							
	15*								30	M6							
18-20	20	45	M6	6.6	6	1.5	16	8	13~15	6.6	34	—					
	25										34	—					
	30								34	—							
	30								34	—							
25	12*	50	M5	5.5	4.5	1.5	17	7	16	5.5	36	M5					
	15*										16~18	38	M6				
	20								16~20	6.6	40	—					
	25								18~20	44	M6						
30	15*	55	M6	6.6	6	1.5	20	10	18~20	6.6	40	—					
	20										18~21	9	45				
	25								18~21	9	45						
	30								18~21	9	45						
35	15	60	M8	9	7	1.5	23	12	21	6.6	48	—					
	20										—						
	25								—								
	30								—								
40	18	70	M8	9	7	1.5	26	13	23	9	56	—					
	30										—						
	30								—								
50	22	85	M10	11	9	1.5	32	16	28	11	68	—					
	30										—						

① FAJ51/52/56 is only suitable for sizes with *.



Part Number	B
Code	D
FAJ01	6
FAJ02	8
	10
	12
	15

FAJ02 — D8 — B8



● Discount price
Per 1~10 11~
Price 100% Additional quotation

