

Code	Type	Material		Surface Treatment
		GB	Equiv.	
BKT01	L Selectable	45	S45C	Black Oxide
BKT02				Electroless Nickel Plating
BKT06		0Cr18Ni9	SUS304	—

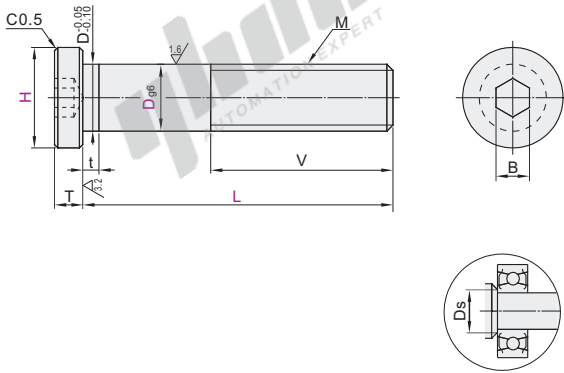

If the screw thread is not specified, it defaults to metric coarse thread, which complies with GB/T 193-2003.



The first perspective

Part Number		H	L	T	B	M	V	t	Ds	Applicable Bearing
Code	D	Select	Select							
BKT01 BKT02 BKT06	4	7	15 20 25 30	2	2	M4	6	0.7	6	674 694 624
	5	8	15 20 25 30		2.5	M5			7	695 605 625 675
	6	9	20 25 30 40		3	M6			8	696 606 626 676
	8	11	20 25 30 40	3	4	M8	8		10	698 608 628 678
		13	20 25 30 40						12	6800
	10	14	20 25 30 40	3	5	M10	12		13	6900 6000
		17	25 30 40						16	6200
	12	15	20 25 30 40 50	3					14	6801
		16	25 30 40 50						15	6901 6001
	15	18	30 40 50 60	3	6	M12	16		17	6201
		18	30 40 50 60						17	6802
	15	19	30 40 50 60	3					18	6902 6002
		21	30 40 50 60						20	6202
	17	20	30 40 50 60	3				1.0	19	6803
		22	30 40 50 60						21	6903 6003
	20	24	30 40 50 60	3	4	8	M16		23	6203
		23	30 40 50 60						22	6804
	20	25	30 40 50 60	3	10	M20			24	6904 6004
		27	30 40 50 60						26	6204
	25	28	30 40 50 60	3					27	6805
		29	30 40 50 60						28	6905
	30	31	30 40 50 60	3	12	M24			30	6005
		33	30 40 50 60						32	6205
	30	33	30 40 50 60	3	5				32	6806
		35	40 50 60						34	6906
		38	40 50 60		14	M30			37	6006 6206



Part Number	H	L
Code	D	
BKT01	14	20 25 30
BKT02	17	25 30 40

BKT01 — D10 — H14 — L30



Discount price
Per 1~9 10~
Price 100% Additional quotation



Delivery
6