

# EU Standard 20 Series Extrusion Accessories-Connection Part

- Leveling mounts Connecting Plate
- Connector

## Leveling mounts Connecting Plate

Code	Type	Material	Surface Treatment
ACF23-206	Leveling mounts Connecting Plate	Carbon Steel	Chrome Plating

Used for connection of extrusion and leveling mounts.



ACF23-206-4420-M12

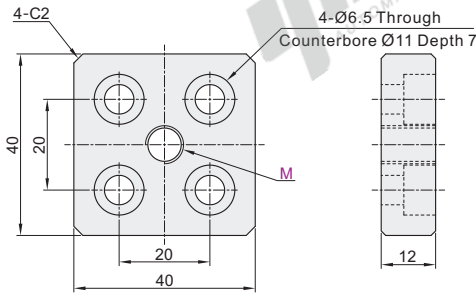

Code	Weight(g/pcs)
ACF23-206-4420-M12	107

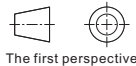

EX

Example

Exploded drawing

Assembly drawing

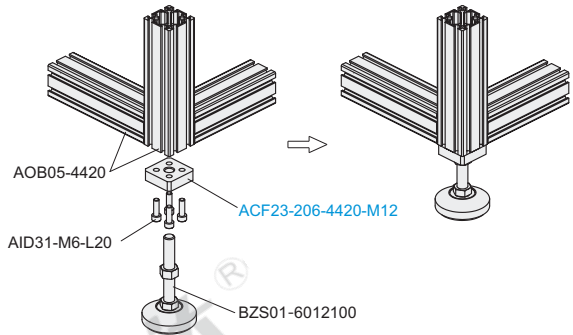

## Built-in Connector

Code	Type	Material	Surface Treatment
ADJ31-206	Built-in Connector	SUS304	Grinding and sandblasting
ADJ42-206		Zinc Alloy	Nickel Plating

Used for internal connection between extrusions at 90 degrees, with high connection strength.

ADJ31-206-D4.5  
ADJ42-206-D4.5

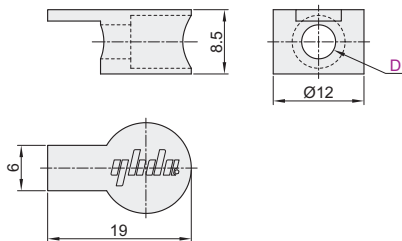

Code	Weight(g/pcs)
ADJ31-206-D4.5	5.1
ADJ42-206-D4.5	4.2



EX

Example

Exploded drawing

Assembly drawing

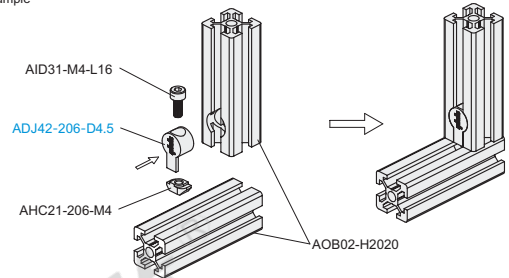

Processing dimension of extrusion:

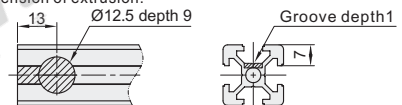

See page P888 for details of post-processing codes.



Code  
ADJ31-206-D4.5  
ADJ42-206-D4.5



Code ADJ31-206-D4.5-SET-OB ADJ42-206-D4.5-SET-OB

Add processing project	Code	Spec.
Equipped with suitable bolts and T-nuts.	SET-OB	When specifying the SET, it is equipped with bolts and nuts for use with connectors. Bolts: AID31-M4-L16 T nuts: AHC21-206-M4 AHC31-206-M4